



History of Pelstar, LLC and Evolution of the Beam Scale



By Rick Crandall © 2010

Pelstar, LLC (see www.homscales.com) designs, manufactures and markets, a comprehensive line of professional products under the 90-year-old venerable brand of Health-O-Meter. Originally formed in 1919 as the Continental Scale Works, its heritage is as the inventor of the “doctor’s” beam scale. Today, Pelstar maintains the tradition as one of the leading producers of weighing instruments for professional health care and medical uses, having returned to market-leading innovation with the release of its Elevate® EMRscale and other advances.

See: Pelstar Awarded Private Company Board of the Year 2016 Click:



<http://www.rickcrandall.net/private-company-boards-of-the-year-2016-named-pelstar/>

The First Personal Scale

The Germans introduced the first bathroom, scale in the early 1910s. The Juraso, named after German inventors Jas Raveno & son used a small mirror at a forty-five degree angle to allow users to read the dial while standing on the scale. The scale became a popular novelty item and was selling worldwide within a few years. Chicago's Marshall Field's department store began carrying the scale in 1913. At the same time, household kitchen scales were gaining in popularity, and a number of U.S. and European companies had entered the market. When World War I started and the supply of Juraso bathroom scales to the United States was cut off, Marshall Fields began looking to U.S. kitchen scale manufacturers for a replacement.

Marshall Field's new bathroom scale was designed by Mathias C. Weber, superintendent of the Chicago Scale Company. Weber had come to the United States as a teenager in 1906 from his native Hungary. His background as a scale mechanic helped to land him a job in New York working on commercial scales for \$16 per week. He soon developed a reputation within the industry as a talented mechanic. He was even called on by the New York City Bureau of Weights and Measures, at the age of 21, as a technical expert to give advice.

In 1914 Weber was hired by Chicago Scale Company -- Chicago Scale's president had ordered a subordinate to hire *"the best scale man in the country."* Shortly after Weber started his job at Chicago Scale, Marshall Fields approached the company about creating a bathroom scale to replace the Juraso.

"Theirs was an ordinary, ball-bearing action mechanism. I had conceived a superimposed parallelogram platform scale using a spring suspension, something I later patented," Weber recalled in *"The Housewares Story."*

"And we also made a big change in the arrangement of the dial.... I happened to glance at the speedometer on the [car] dashboard ... 'That's it!' I shouted ... 'we'll place the dial in such a position that it can be easily read when you're standing on the scale.'"

The innovative scale was introduced in 1917 and marketed at a price of \$7.50 which was \$2.50 less than the Juraso.

"We got a letter [from the maker of the Juraso] warning us of the serious consequences if we copied their scale! We had a good laugh and went back to work."

1919: The Birth of the Continental Scale Works and the Health-O-Meter Brand

For some time Weber had considered starting his own scale business. At home, he had even developed a new scale that he called the "Health-O-Meter." He filed for a patent on the scale in January, 1917.

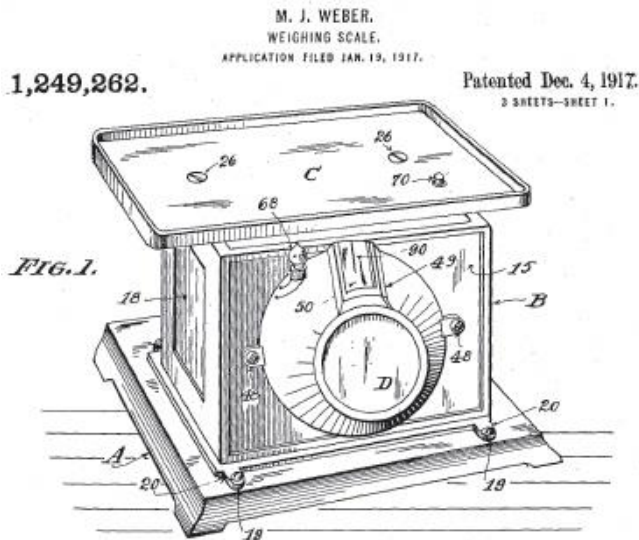

Through his barber, Weber met a wealthy investor named Irving King Hutchinson. In 1919, Irving and his brother Alfred joined Weber to form the Continental Scale Works to begin manufacturing Weber's design. That same year they began building and selling the Health-O-Meter Model No. 100 bath scale. The scale had a cast-iron frame and incorporated an accurate rack and pinion system with hardened bearings. Selling for \$16, the scale weighed 20 pounds, and stood eight inches tall.

Its accuracy was guaranteed to within one pound. Despite a drum-type dial that was somewhat difficult to read from a standing position, the scale was quickly accepted in the marketplace and Continental's sales surged.

The demand growth was partly attributable to



Health-O-Meter original Model 100 bath scale with drum-type dial

the dieting fad that began in the United States following World War I. Prior to World War I most people measured their weight on coin-op novelty machines that cost a penny. After the war, a slim figure was considered fashionable for women and the concept of an at-home scale was appealing. Continental Scale Works continued to benefit from Weber's inventive product introductions. In 1921, for example, Weber patented the horizontal clock-face scale dial. This was a large highly visible horizontal dial, although the step was still raised on an 8" high platform.

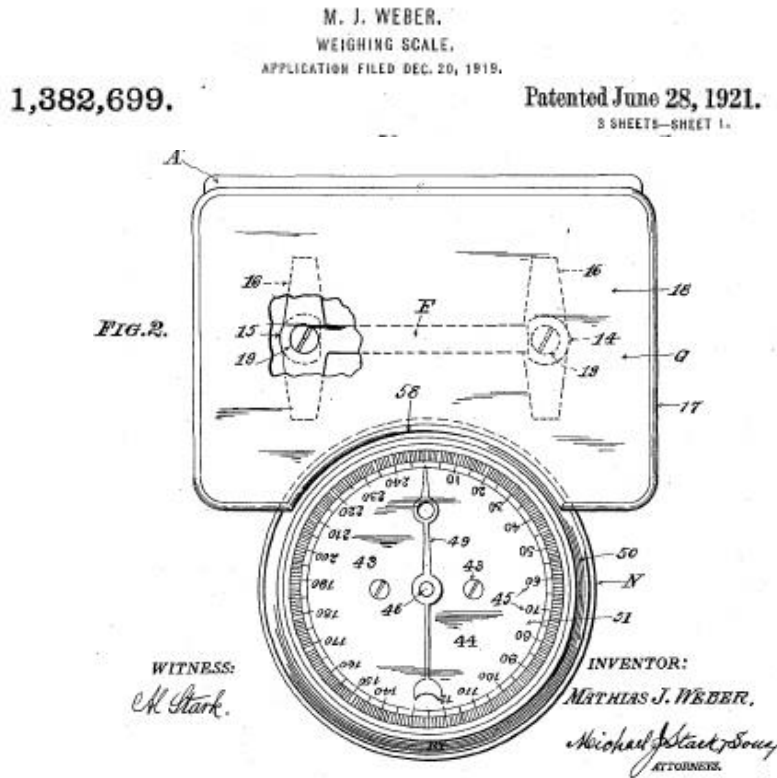

Second model, Health-o-Meter bath scale featuring large clock-face dial.

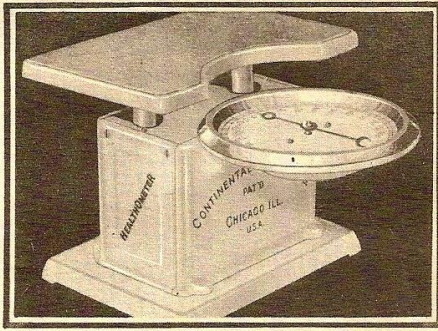

Health-O-Meter

"for every member of the family"

WATCH your weight on the original "Health-O-Meter" designed by specialists. Approved and certified accurate by Bureaus of Weights and Measures in United States and Canada. Will last a life-time. Our broad guarantee is attached to every scale. Sturdily constructed, handsomely enameled in white. Dimensions 8"x10x12". Capacity 250 lbs. by one pound graduations. 300 lb. capacity to order. Legible glass covered dial registers instantly and automatically. No adjustments necessary. Thousands are in use today. Accept no substitute. Ask for the original "Health-O-Meter" by name. A complete course of instruction on "Scientific Weight Control" endorsed by physicians, is sent free with every scale.



**HEALTH
BEAUTY
SUCCESS
HAPPINESS**

*all
depend on
your
weight*



*Insure
Correct
Weight
with*

Health-O-Meter

Early 1920's Color Flyer

*The helpful psychology
... of weighing daily*

Health-O-Meter Standard

The world's best known scale; used by millions daily. Requires but 10½" x 13" floor space. Same colors as De Luxe model. . . \$10.95



Health-O-Meter Roto-Dial

Compact—takes but 10½" x 8" floor space because of speedometer type dial. Same colors as De Luxe model. . . \$8.95



It's Fun

*... to weigh on a
Health-O-Meter*

All you do is to get on. A big arrow flashes around and tells you your exact weight. Weighing yourself every day on a Health-O-Meter is great sport.



Ask to have a

HEALTH-O-METER

... put in your bathroom

It's nice to know how much you weigh today and how much you have gained since last week. * Your parents will be glad to have you weigh daily so that they can be sure you are growing as you should.

\$15.00 Delivered East of the Rockies *

CONTINENTAL SCALE WORKS
5701 S. Claremont Ave. Dept. 48-E Chicago

1920's ad clip showing both bath scales

1927 Ad

1920: Continental's Weber Invents the Doctor's Beam Scale

In 1920, Weber made a major departure with the conception of the eye-level doctor's scale, which was quickly filed for patent protection. This scale, with remarkably few improvements over the years, became a standard fixture in doctor's offices and medical facilities throughout much of the world.

The major innovations embodied in this scale were the accuracy achieved with the sliding weights on a calibrated beam, and the height rod enabling the reading of both the height as well as the weight. The second patent drawing closely resembles the scale that was actually produced and sold commercially. The head of the scale can be seen with a cut-out pattern in the casting that was one of several ways in which the scale was made lighter as called out in the patent claims – to save materials costs and shipping.

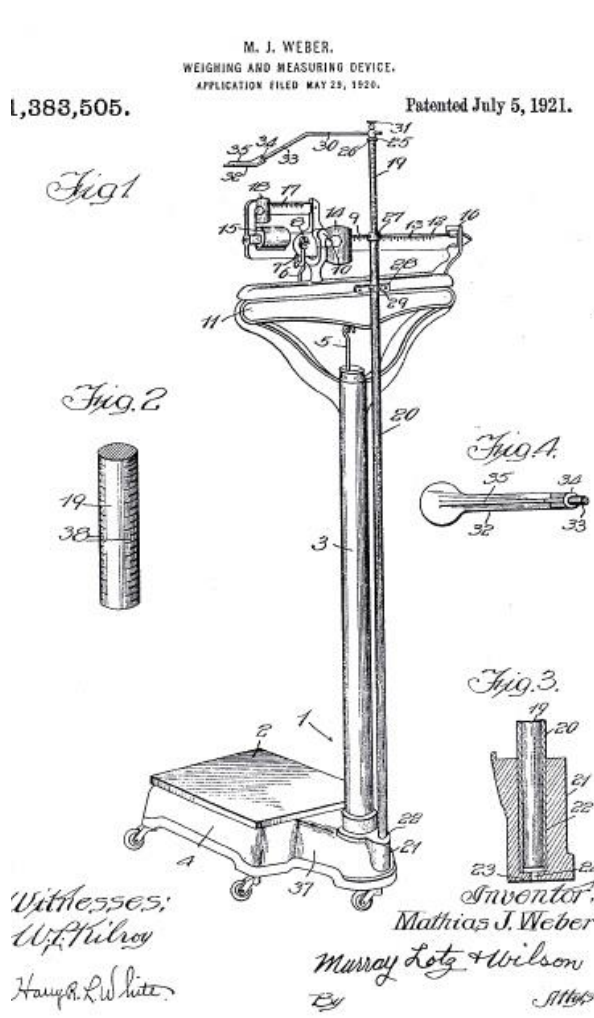

First Beam Scale Patent Filed May, 1920

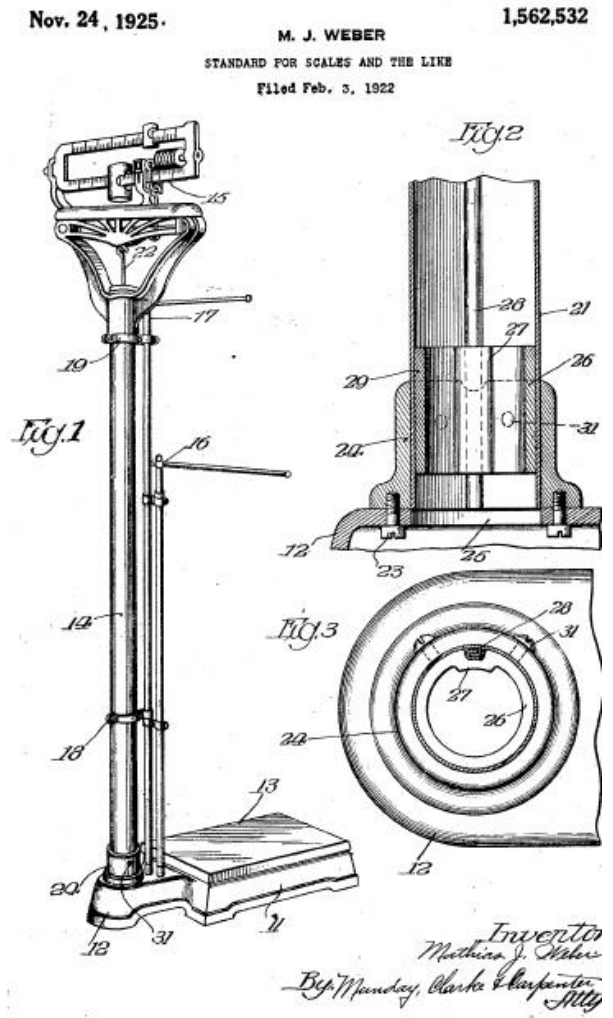

Second Beam Scale Patent Filed Feb, 1922

An extant example of the first physician's beam scale is shown below in restored condition (left) and the equivalent Model 402KL scale as it is sold today, 90 years later (right)



**First Physician's Beam Scale,
Ser. # 13395, circa 1920**



**Health-o-Meter Professional
Model 402KL, circa 2010**

Know Your Weight

A **CONTINENTAL SCALE** in your bathroom will enable you and every member of your family to obtain their true weight without clothing as often as desired.

Accurate and sensitive yet strong and durable, beautifully finished in white enamel with nickel-plated brass fittings.

Write today for descriptive booklet and the name of the dealer near you who carries these super-scales.



Continental Scale Works
3905-11 LANGLEY AVENUE
CHICAGO, ILL.

Ad from June, 1920 Republican National Convention Program

The early ads for this scale still spoke of using it in home bathrooms, although advertising was placed in medical publications. Its accuracy was undoubtedly the key to acceptance by doctors and medical institutions.



Serial #13395 from rear showing tag



Nurses Lightweight Portable Scale

for Weighing and Measuring Babies, Children or Adults at Rural Schools, Welfare Stations and General Field Service

Can you imagine a handier equipment than a **scale** LIGHT ENOUGH for you to handle in transportation, yet possessing every worth-while **scale** feature. You can set the **Continental scale** up in less than two minutes. There is no lighter **scale** made, yet none is more efficient.

CONTINENTAL
Nurses Lightweight Portable Scales

are designed and built to serve the rigid requirements of traveling nurses. Every **Continental scale** is designed for a given purpose and meets it thoroughly and efficiently. **Continental Scales** are accepted everywhere, for professional use—and there's a reason!

Learn more about the **Continental Nurses Lightweight Portable Scale**. The "Continental Seal of Accuracy" is your quality protection and guarantee.

Literature on the **Continental Nurses Lightweight Portable Scale** is yours for the asking. Write for it today.

CONTINENTAL SCALE WORKS
2122 West 21st Place, Chicago, Ill.
72 Murray Street, New York City

Model No. 526
Capacity 210 lbs.
Graduated in Ounces.

With carrying case, ready for any method of transportation.

Sent on approval if desired



1921 Ad from Nations' Health Volume 3

Continental, with its patented Health-O-Meter line, became the leading household scale manufacturer in the world during the 1920s - 1930s.

Competitors soon joined the fray. Detecto (Jacob Brothers) entered the bath scale business in 1921. This started a whole series of infringement cases that went on for years. However, Weber was generally acknowledged as the father of the US personal scale industry. He was not only incredibly inventive, but his scale company was also very aggressive in using its patent library to defend and attack would-be new entrants. While it is estimate over 30 scale manufacturers entered the market, few ever made it to profitability. Health-O-Meter rose to be the dominant brand in the 1930's.

Continental gradually lost much of its market dominance, as imitators came and went but during their short lives they affected the market. Among the best-known imitations was the short-lived "Princess" bath scale, which was a low-platform scale developed by a young German immigrant named Carl Burkhardt. Burkhardt was working for Narlor Heather Company of Indiana when that company introduced his Princess scale design in 1934. Narlor unveiled the low-slung scale at a home show in Chicago. Incredibly, the scale was priced at only \$1.25. It became the talk of the home show, and Narlor won a huge order for 50,000 of the scales from Sears, Roebuck and Company.

When Weber was finally able to examine the scale, he was dismayed to discover that its internal mechanism was a direct copy of the one he patented for the Health-O-Meter. After a difficult fight, Weber won a court order to stop the company from selling the Princess.

Throughout the 1920s - 1940s Weber spent much time and resources working to protect his patents. Other scale makers persevered, introducing their own innovations intensifying the competition.

During the 1930s, scale makers worked to distinguish their scales from the growing herd of models by focusing on fashion. The 8" high, box-like scales were eventually replaced by low platform designs that were offered in a number of colors, shapes, and styles. Continental met market demands with new scales and remained an industry innovator and leader for several years.

During the post-World War II U.S. economic and population boom, demand for bathroom scales rocketed and sales of Health-O-Meter scales increased. By the 1960s, in fact, bathroom scales had become a common fixture in American homes. By the early 1970s, moreover, Americans were purchasing more than 6 million bathroom scales annually. Eventually the bathroom scale market began to slow in the 1970s, and by the late 1970s sales flattened. As competition in the bathroom scale arena heated up during the 1960s and 1970s, Continental focused its resources on the less crowded market for beam scales sold to doctor's offices and other commercial markets.

1982: Continental Becomes the Lee-Continental Corporation

Continental experienced turbulence during the 1980s. Continental became Lee-Continental Corp. after investment company Thomas H. Lee Co. purchased a major interest. Indeed, the scale market stagnated in the early 1980s and remained that way throughout the decade. By

the early 1980s Lee-Continental had, in effect, become a semi-successful manufacturer of high-end scales for doctors' offices. Annual sales were mired in the \$15 million range, and growth prospects appeared negligible. The Health-O-Meter brand ceded dominance of the bathroom scale market to Sunbeam-Oyster and Illinois-based Counselor Co., a division of Newell Co. in the mid-1980s. Attempting to boost sales and earnings, Lee-Continental purchased some other companies through leveraged buyouts (LBO's) in 1984 and 1988, which expanded its presence in markets for household scales and timers. The LBOs were conducted under the direction of Lawrence Zalusky, who became president of the company in 1984.



Health-O-Meter Bigfoot Scale

Mart account to the increasingly competitive Continental.

By expanding into new markets, lowering prices, and chasing the mass retail market, Zalusky managed to regain some of Continental's old glory. Sales rose at the fast pace of 19 percent annually, reaching \$46 million by the early 1990s. Much of the gain was the result of Continental's reemergence as a leader in bathroom scales. Importantly, in 1989 Continental borrowed an idea from a successful scale importer to design the Bigfoot bathroom scale. The Bigfoot series of bathroom scales featured speedometer-like, oversized readouts that were an instant hit. Within three years the Bigfoot scales were accounting for about 30 percent of Continental's revenues. Continental's gains in the bathroom scale industry were made largely at the expense of Counselor Corp. Counselor suffered a long slide in the market that was capped by the loss of most of its giant K-

“Scale Firm Weighs In With First Ads”

June 03, 1991/By George Lazarus.

“Hershey might be the corporate classic among advertising holdouts, finally yielding in 1968 to consumer confectionery promotion after 66 years on the sidelines.

“Though hardly an earthshaking development to equal Hershey’s turn to Madison Avenue, a Bridgeview bathroom scale firm, Health o meter Inc., is learning in 1991 whether it pays to advertise to consumers.

“And considering that Health o meter and its predecessor, Continental Scale, have been around since 1919, perhaps this foray into media hype may shake up what is a \$175 million business at retail. Now Health o meter, one of the three top players in bathroom scales, the others being Newell Co.’s Counselor Division and Sunbeam, is about to take the plunge on the tube.

“The firm is readying a spot TV market test for the fall for some of its upper-end or professional scales, priced in the \$60-to-\$100 range at retail. This test involves Health o meter’s Big Foot line, very elaborate professional floor scales.

“Bathroom scales can range in price from less than \$10 to more than \$200, the higher prices offering better profit margins, of course. Getting consumers to trade up from the simple mechanical analog scale to a digital or professional model or a doctor’s scale isn’t so easy.

“However, Health o meter is clearly the leader in professional scales, which account for 7 percent of total units sold. That total this year will be an estimated 7.4 million units, with all professional scales accounting for 25 percent of dollar volume.

“About 80 percent of households have scales, and three-fourths have scales in the bathroom. There is very little brand recognition in the category; only 5 percent of scale owners know the name of the make they own. Purchases are primarily for replacements, scales usually lasting eight years.

1992: Renamed Health-O-Meter Products, Inc.; Went Public (NASDAQ: SCAL)

Despite sales gains, Continental suffered net losses in both 1990 and 1991. The company went public in 1992 as Health-O-Meter Products Inc. as part of an effort to raise cash. Zalusky used the \$30 million in proceeds to pare the company's debt and, among other things, invest in new marketing and product development. By early 1993 Health-O-Meter was once again boasting a dominant 60 percent of the U.S. scale market and was also enjoying success with new overseas operations.

In 1993, Thomas H. Lee Co., the same investment enterprise that owned 35 percent of Health-O-Meter, engineered the purchasing a controlling interest in Mr. Coffee, (drip coffee-makers). The \$135 million deal resulted in Health-O-Meter taking over the operations of Mr. Coffee. Lee moved Health-O-Meter's corporate offices to Mr. Coffee's headquarters in Ohio. Zalusky became a director on the board. Lee planned to combine the two companies to benefit from economies of scale in administrative and manufacturing activities.

Combined sales for Health-O-Meter and Mr. Coffee during 1994 approached \$250 million and were rising steadily going into 1995 when Health-O-Meter was employing a work force of about 1,000 in all of its operations. Its two primary divisions were Mr. Coffee and Health-O-Meter/Pelouze. The latter division comprised a wide array of mechanical and digital scales, massagers, and timers for home use, as well as high-end scales for professional use. Those goods were sold primarily through discount merchandise chains, but also through catalogs, department stores, and mail order companies. The larger Mr. Coffee division still emphasized drip coffeemakers and tea-makers, but during the early 1990s also branched out into various kitchen appliance products, including water filters, potato baking devices, juicers, food dehydrators, and bread-makers. Although the company was still battling a relatively heavy debt load from the Mr. Coffee acquisition, improving sales and cash flow helped Health-O-Meter's short-term future.

1997: Renamed Again: Signature Brands

Bedford Heights, OH--March 31, 1997 (Signature Brands Press Release)

The New Name Allows for the Acquisition and Development of Other Signature Brands

The shareholders of Health o meter Products Inc., parent company of Mr. Coffee®, Health o meter® and Pelouze® brand products, have voted to change the company name to Signature Brands USA Inc.

The name change, which was approved at the company's annual shareholder's meeting earlier this month, will result in a new Nasdaq trading symbol as well. Effective April 1, 1997, the current ticker symbol, SCAL will be replaced by SIGB.

Steven M. Billick, the company's chief financial officer, said, "Changing our company name to Signature Brands is the first step in changing the strategic direction of the company. It signals that the merger of Health o meter and Mr. Coffee has been completed. The new name better communicates our ongoing strategy of expansion via well recognized brand names. Signature Brands is now the umbrella under which powerful brand names like Health o meter, Mr. Coffee and Pelouze will thrive."

Health o meter Products Inc. acquired Mr. Coffee in 1994. As the company has continued to grow, the duality of a corporate and brand name has been somewhat unclear to customers, consumers and the investor community.

1998: Signature Brands Acquired by Sunbeam

The re-positioning of the company as a multi-brand, growing company attracted Sunbeam who was in an acquisitive mode just one year later:

Delray Beach, Fla.--March 2, 1998

Sunbeam Corporation initiated an aggressive expansion strategy today with the announcement of the acquisitions of three separate market leading durable consumer product companies. These transactions will enhance shareholder value by nearly tripling the Company's annual revenues, expanding its geographic presence, complementing its existing product lines and leveraging operational synergies. The three transactions will total approximately \$2.5 billion and will be meaningfully accretive to Sunbeam's earnings within twelve months.

Signature Brands USA, Inc. (NASDAQ:SIGB) with 1997 revenues of \$279 million is the North American leader in coffee makers marketed under the Mr. Coffee® brand name and is a leader in consumer health products marketed under the Health o meter® brand. The Company, based in Glenwillow, OH, operates two manufacturing facilities and employs approximately 1,000 people. The transaction is valued at approximately \$250 million consisting of a cash tender offer of \$8.25 per SIGB share and the assumption of existing debt.

Albert J. Dunlap (aka "Chainsaw Al"), Sunbeam's chairman and chief executive officer stated, "The successful turnaround of Sunbeam, including the dramatic improvement of the underlying business, has provided us with a solid platform for profitable growth. These three separate transactions represent the next phase of our plan to create value for Sunbeam's shareholders. We looked at various alternatives to increase shareholder value. Ultimately we decided there is phenomenal value to be created in assuming the leadership role in consolidating the industries in which we compete. These acquisitions enable us to accelerate our growth rate by expanding our geographic presence, entering new product lines and leveraging the strength of dominant brand names such as Coleman®, Camping Gazi®, Eastpak®, First Alert®, Mr. Coffee®, and Health o meter®, along with Sunbeam®, Oster® and Grillmaster®."

Mr. Dunlap added, "Our strategy is to become the global leader in the durable consumer products industry through continued internal growth augmented by further strategic acquisitions of high quality consumer brands. Our proven track record coupled with our financial strength will enable us to successfully execute this strategy."

2001: Just Two Years Later Sunbeam files Bankruptcy

Saddled By Debt, Sunbeam Files For Chapter 11 Shelter

February 07, 2001 from Tribune News Services.

BOCA RATON, Fla. — Struggling appliance maker Sunbeam Corp., owner of brands such as Mr. Coffee, First Alert and Coleman, filed for Chapter 11 bankruptcy protection Tuesday to reorganize its operations.

The filing in U.S. Bankruptcy Court in the Southern District of New York came as Sunbeam was unable to resolve a \$2.6 billion debt load. Its troubles were exacerbated by the cost of lawsuits filed by shareholders, whose stock became virtually worthless after the company restated its profits and losses from 1996 to 1998, wiping away \$61 million in reported profits.

As part of the restructuring, Sunbeam will lose its nine-year listing on the New York Stock Exchange and turn private, Chief Executive Jerry W. Levin said Tuesday. Banks that have agreed to provide Sunbeam with a \$235 million credit line will hold 100 percent of the firm's stock.

February, 2002: Pelstar Purchases Health-O-Meter Professional and Pelouze Postal Scale Business from Sunbeam



Sunbeam underwent major restructuring efforts to navigate its bankruptcy proceedings. One of its strategies was to focus on its consumer products businesses while divesting other business units that serve business and professional markets. Among the business units targeted for sale were the Health-O-Meter brand of professional medical scales and the Pelouze brand of postal and food service scales. In mid-2001, Paul Nizzere, who had been the marketing executive at Pelouze in the late 1980's and with Health-O-Meter Inc. until his departure in 1997, heard of the possibility of the divestiture. He approached a private equity group, Aspen Partners, LLC with the idea of financing the buyout.

Negotiations and financing of the buyout concluded successfully in November, 2001 and closed in February, 2002 when the Pelouze and the professional segment of Health-O-Meter medical scale businesses were purchased into newly formed Pelstar, LLC with Nizzere as CEO and the Board managed by Aspen Partners. Sunbeam kept the consumer side of the Health-O-Meter business.



November 6, 2001 (Sunbeam employee memo)

Back in August of this year, we announced that Sunbeam was pursuing the sale of assets related to our Professional Scales business, which is comprised of Pelouze postal and food scales and Health o meter medical scales. Today, I am pleased to announce that Pelstar, L.L.C., has signed an agreement under which it will acquire the Professional Scales business from Sunbeam.

Pelstar, L.L.C. is a newly created company formed by a group of investors with significant experience with both scales manufacturing and the marketing of products into professional trade channels, as well as significant ties to the Chicago area. Included in this group is Paul Nizzere, who is the former General Manager of the Professional Scales business, and who is the newly appointed President and Chief Executive Officer of Pelstar.

The decision by Sunbeam to sell the Professional Scales business is a result of the Company's need to restructure its debt and streamline operations in order to improve Sunbeam's competitive position. As part of this restructuring, as was previously announced, Sunbeam has decided to focus its efforts on consumer retail scales as part of the company's core competency in both consumer appliances and consumer-oriented distribution channels.

We firmly believe that this sale to Pelstar will provide the best outcome for all constituents, including the Company's customers and its employees at Bridgeview and Aurora....

Pelstar immediately set a strategy to re-vitalize the product line with freshened designs and energized responsiveness to channel partners that had suffered from neglect under the Chainsaw AI cost-cutting regime in Sunbeam.

Within two years the market saw new scale innovations from the Pelstar team including a new digital generation of the long-standing “doctor’s scale:”



New Health-O-Meter Scales for 2004:

- Advanced Digital Designs
- Modular, Upgradeable
- User Focused, Ergonomic
- USB and Network Connectivity

2004: Pelstar Becomes a Medical Products Pure-Play with the Sale of Pelouze

The Pelouze division of Pelstar served a combination of consumer and small business markets with substantial reliance on the “big box” retailers who were accomplished at eliminating the profitability of its smaller suppliers. The Pelstar Board made the strategic decision to sell the Pelouze business and was successful in that effort. The Pelouze division of Pelstar (the Office, Industrial and Food Service products of the Company) was sold to the Newell/Rubbermaid Company. The transaction closed on January 9, 2006. The assets, products and people associated with the Pelouze-branded products were transferred to Newell, including Paul Nizzere.

Dan Maeir, who had been the Pelstar executive in charge of finance and operations, was promoted to CEO. Pelstar co-founder and Board member Rick Crandall, the managing partner of Aspen Partners who had originally negotiated the purchase agreements with Sunbeam, and is the largest shareholder of Pelstar, assumed the Chairman of the Board position.

With its new-found focus on medical and health scales, Pelstar kicked into overdrive to regain its position as a growth company. Professional sales management was hired, new product inventions were conceived and a game plan for international expansion was put into place with WelchAllyn as a powerful partner. Then Obamacare was passed into legislation, with a strong focus on recording weight, height and body mass index (BMI) as key inputs to an electronic medical record (EMR) initiative.



Modern version of the original mechanical doctor's beam scale.



Digital "doctor's scale:" with height rod, 2009 version Model 500KL



Wheel-chair scale with patented electronic head

January 6th, 2010 Pelstar Ships the 15 Millionth Medical Scale



HEALTHCARE NEWS
For Immediate Release

15 MILLIONTH
HEALTH O METER® PROFESSIONAL SCALE SHIPPED

January 6, 2010

The maker of the world's leading **Health o meter® Professional** scales, Pelstar LLC, announced that they shipped their 15 millionth medical scale today to New Jersey. The 2595KL digital chair scale shipped was one of many going out. Health o meter® Professional is the world's most recognized brand in medical weighing and a leader in scale sales, with expertise gained from being in the business for nearly a century, designing and selling premiere weighing instruments to medical professionals throughout the world.



2010: U.S. Government Passes Stimulus and Health Care Bill Mandating Height, Weight and Body Mass Index (BMI) to be Captured for Electronic Health Records

Without opining on the soundness of the hotly contested 2010 legislative enactments commonly called “the Stimulus Act” and “Obamacare,” Pelstar officials set about studying the new requirements that were aimed at a rising obesity trend. U.S. Government studies indicated that the simplest measure of over-weight and obesity conditions were reflected in a metric called Body Mass Index or BMI. This metric is a calculation involving weight and height – and is mandated to be captured electronically and transmitted to electronic medical records (EMR’s) and a national data base of all U.S. citizens.

Pelstar was already working on the invention of a digital height rod for its electronic doctor’s scale, and given the new legal requirements, efforts to patent and produce such a scale were accelerated, resulting in its announcement in late 2010:



Health-O-Meter® EMRscale®
 (watch video at www.homscales.com)

- **Digital Height Rod** – measures height electronically, avoiding manual input errors
- **Weight** – measured electronically
- **BMI** calculated instantly and using on-board computer
- **All data transmitted** to a wide variety of EMR devices & software

Electronic & Connected ...



“American Recovery Act of 2009:”

By 2014, being “compliant” will mean capturing weight, height and BMI automatically, not manually. Those who are not compliant will lose Federal subsidies and suffer diminished Medicare and Medicaid payments.

Slide from Pelstar presentation on its release of Elevate, EMRscale.

2011: Pelstar Expands Globally in Partnership with WelchAllyn

Health-O-Meter's presence in the professional markets has predominantly been in the North American markets with some distribution in Latin America. Its geographic expansion became complete with a landmark exclusive partnership with WelchAllyn, leveraging their wide-ranging international presence.



For More Information Contact:

Jamie Arnold, APR

Public Relations Manager

+1.315.685.4599

[*arnoldj@welchallyn.com*](mailto:arnoldj@welchallyn.com)

Welch Allyn Partners with Pelstar, LLC to Co-Brand, Distribute Health o meter® Professional Medical Scales Outside the United States and Canada

Collaboration Adds Vital Signs Solution to Welch Allyn International Product Portfolio

Skaneateles Falls, NY, USA, November 4, 2010—Welch Allyn, a leading global provider of medical diagnostic equipment, today announced it has partnered with Pelstar, LLC, maker of Health o meter® Professional Scales, to co-brand the Health o meter line of professional medical weight scales for distribution in markets outside the United States and Canada.

The agreement will allow Welch Allyn to offer for the first time a line of high-quality professional medical weight scales as part of its existing portfolio of vital signs devices aimed at giving frontline care providers quick and accurate ways to assess, diagnose and treat patients in low-acuity settings. In turn, Pelstar, which holds the number one market position in the U.S. for professional medical scales, will now have the opportunity to expand into various high-growth international markets by leveraging the wide-reaching distribution channels of Welch Allyn. Health o meter Professional Scales have been distributed by Welch Allyn in Latin America for nearly 20 years, and both companies expect the enhanced partnership to allow for greater opportunities in Europe, Middle East, Africa and Asia.

... and this tale of corporate and brand re-invention continues ...

References:

Crandall, Rick, Original files and papers circa 2002.

Hanssen, Stan B., *Book of Scales*, self-published, 2007

Lifshey, Earl, *The Housewares Story: A History of the American Housewares Industry*, Chicago; National Housewares Manufacturers Association, 1973

Mote, Dave, "Health o meter Products Inc.," *International Directory of Company Histories, Volume 14*, 1996, St. James Press

Murphy, H. Lee, "Health O Meter Set to Weigh in with Home Health Care Items," *Crain's Chicago Business*, April 20, 1992, P. 52

Oloroso, Arsenio Jr., "Spending Adds Weight to Scale Firm's Profits," *Crain's Chicago Business*, May 31, 1993, p. 18

U.S. Patent Office, patents 1,249,262; 1,382,699; 1,383,505; 1,562,532